

**WORLD COLLEGE OF TECHNOLOGY AND MANAGEMENT
GURGAON**



IMPORTANT QUESTIONS AND ANSWERS

SUBJECT: COMPUTER NETWORKS

COMMON TO: B.TECH (IT, ECE, CSE)

SEMESTER: 5TH AND 6TH

CODE: IT-305-F

Prepared By: - Mr. Manoj Kumar

MCA Department, WCTM



Question No. 1

Define computer networks? Discuss various types of networks topologies in computer network. Also discuss various advantages and disadvantages of each topology.

Answer:-

“Computer network” to mean a collection of autonomous computers interconnected by a single technology. Two computers are said to be interconnected if they are able to exchange information. The old model of a single computer serving all of the organization's computational needs has been replaced by one in which a large number of separate but interconnected computers do the job. These systems are called computer networks.

Network topologies:

Network topology defined as the logical connection of various computers in the network.

The six basic network topologies are: bus, ring, star, tree, mesh and hybrid.

1. Bus Topology:

In bus topology all the computers are connected to a long cable called a bus. A node that wants to send data puts the data on the bus which carries it to the destination node. In this topology any computer can data over the bus at any time. Since, the bus is shared among all the computers. When two or more computers to send data at the same time, an arbitration mechanism are needed to prevent simultaneous access to the bus.

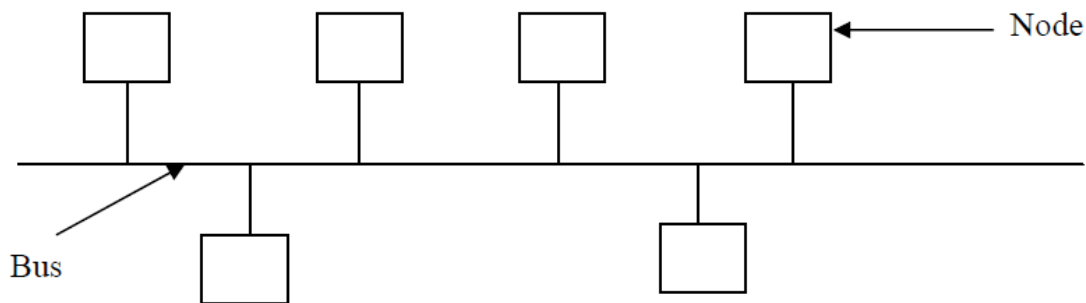

BUS TOPOLOGY

A bus topology is easy to install but is not flexible i.e., it is difficult to add a new node to bus. In addition to this the bus stops functioning even if a portion of the bus breaks down. It is also very difficult to isolate fault.

2. Ring Topology:

In ring topology, the computers are connected in the form of a ring. Each node has exactly two adjacent neighbors. To send data to a distant node on a ring it passes through many intermediate nodes to reach to its ultimate destination.

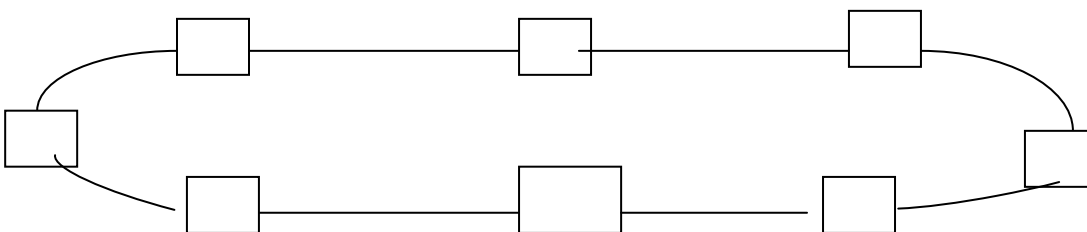

A ring topology is as to install and reconfigure. In this topology, fault isolation is easy because a signal that circulates all the time in a ring helps in identifying a faulty node. The data transmission takes place in only one direction. When a node fails in ring, it breaks down the whole ring. To overcome this drawback some ring topologies use dual rings. The topology is not useful to connect large number of computers.

3. Star Topology:

In star topology all the nodes are connected to a central node called a hub. A node that wants to send some data to some other node on the network, send data to a hub which in turn sends it to the destination node. A hub plays a major role in such networks.

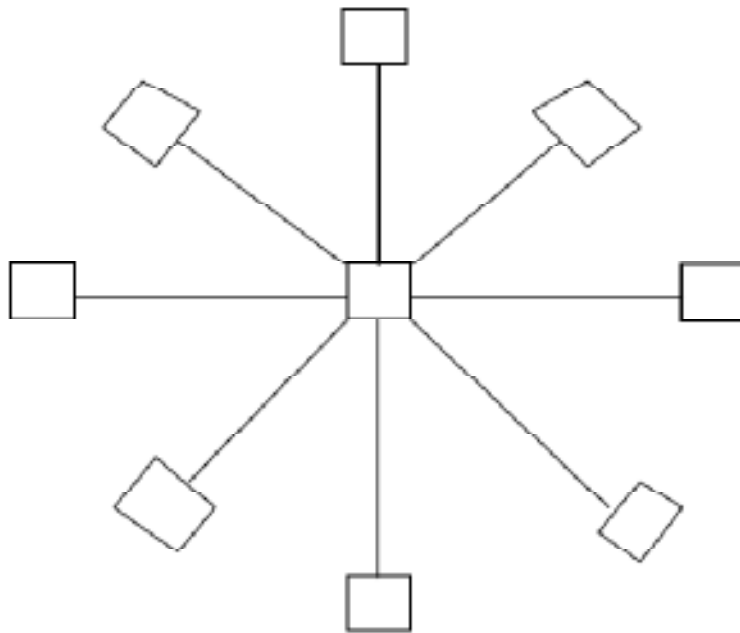

STAR TOPOLOGY

Star topology is easy to install and reconfigure. If a link fails then it separates the node connected to link from the network and the network continues to function. However, if the hub goes down, the entire network collapses.

4. Tree Topology:

Tree topology is a hierarchy of various hubs. The entire nodes are connected to one hub or the other. There is a central hub to which only a few nodes are connected directly. The central hub, also called active hub, looks at the incoming bits and regenerates them so that they can traverse over longer distances. The secondary hubs in tree topology may be active hubs or passive hubs. The failure of a transmission line separates a node from the network.

5. Mesh Topology:

A mesh topology is also called complete topology. In this topology, each node is connected directly to every other node in the network. That is if there are n nodes then there would be $n(n - 1)/2$ physical links in the network.

As there are dedicated links, the topology does not have congestion problems. Further it does not need a special Media Access Control (MAC) protocol to prevent simultaneous access to the transmission media since links are dedicated, not shared. The topology also provides data

security. The network can continue to function even in the failure of one of the links. Fault identification is also easy. The main disadvantage of mesh topology is the complexity of the network and the cost associated with the cable length. The mesh topology is not useful for medium to large networks.

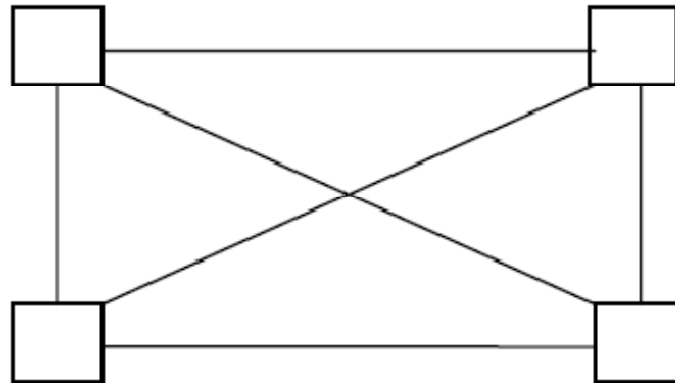

MESH TOPOLOGY

6. Hybrid Topology:

Hybrid topology is formed by connecting two or more topologies together. For example, hybrid topology can be created by using the bus, star and ring topologies

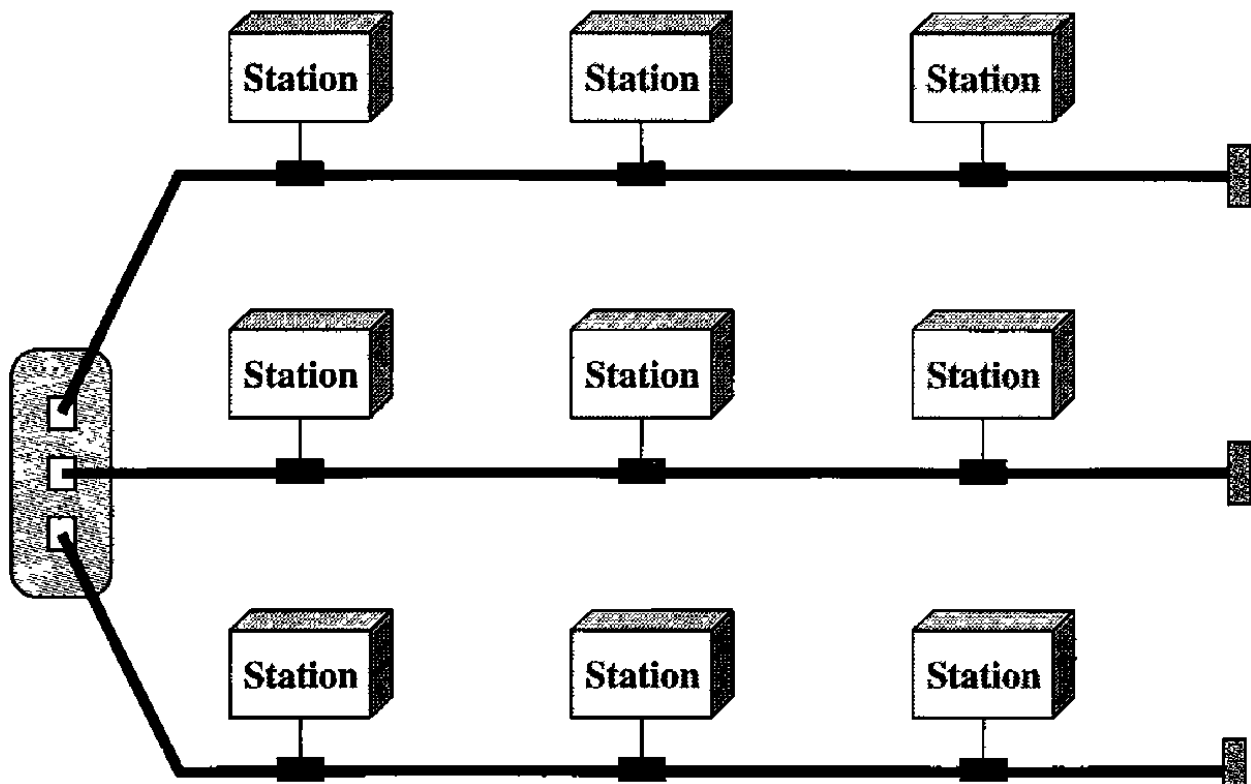

HYBRID TOPOLOGY

Question No. 2

What are the applications of Computer Networks?

Answer:-

1. Information:

One of the applications of computer networks *is* the ability to provide *access* to remote information.

- Pay bills; carry out transactions on bank accounts etc.
- Shop from home by inspecting the catalogs of thousands of companies available online.
- Ask the newspaper for full information about your interesting topics such as corrupt politicians, big fires, football and so on.
- Access information about health, science, art, business, cooking, sports, travel, and government and so on. All this is available on the information systems like the World Wide Web (WWW).

2. Communication:

The popular application of computer networks is electronic mail or e-mail which widely used by millions of people to send and receive text messages. With real-time e-mail, remote users can Communicate even by see and hear each other at the same time. It is also possible to have virtual meetings called videoconference on-line among remote users.

3. Entertainment:

A huge and growing application is entertainment. It entertains people by allowing video demand, and has multiple real-time games etc.

Question No. 3

What is OSI Model? Explain the functions and protocols and services of each layer?

Answer: - The OSI Reference Model:

The OSI model (minus the physical medium) is shown in Fig 4. This model is based on a proposal developed by the International Standards Organization (ISO) as a first step toward international standardization of the protocols used in the various layers (Day and Zimmermann, 1983). It was revised in 1995(Day, 1995). The model is called the ISO-OSI (Open Systems Interconnection) Reference Model because it deals with connecting open systems—that is, systems that are open for communication with other systems. The OSI model has seven layers. The principles that were applied to arrive at the seven layers can be briefly summarized as follows:

1. A layer should be created where a different abstraction is needed.
2. Each layer should perform a well-defined function.
3. The function of each layer should be chosen with an eye toward defining internationally standardized protocols.
4. The layer boundaries should be chosen to minimize the information flow across the interfaces.
5. The number of layers should be large enough that distinct functions need not be thrown together in the same layer out of necessity and small enough that the architecture does not become unwieldy.

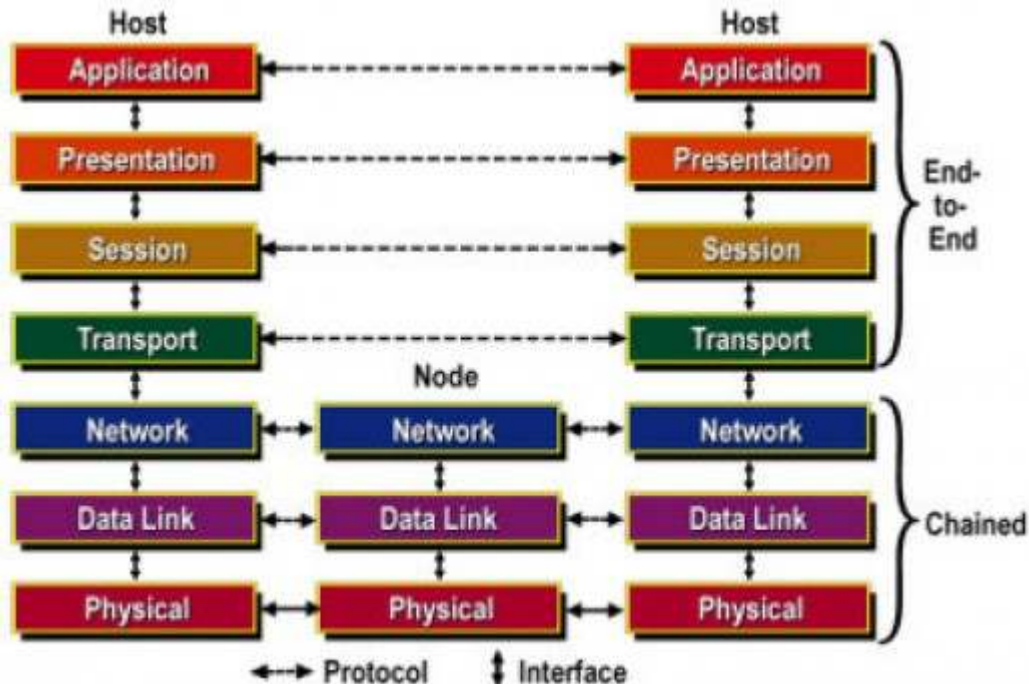

THE OSI REFERENCE MODEL:

1. The Physical Layer:

The physical layer is concerned with transmitting raw bits over a communication channel. The design issues have to do with making sure that when one side sends a 1 bit, it is received by the other side as a 1 bit, not as a 0 bit.

2. The Data Link Layer:

The main task of the data link layer is to transform a raw transmission facility into a line that appears free of undetected transmission errors to the network layer. It accomplishes this task by having the sender break up the input data into data frames (typically a few hundred or a few thousand bytes) and transmits the frames sequentially. If the service is reliable, the receiver confirms correct receipt of each frame by sending back an acknowledgement frame. Another issue that arises in the data link layer (and most of the higher layers as well) is how to keep a fast transmitter from drowning a slow receiver in data. Some traffic regulation mechanism is often needed to let the transmitter know how much buffer space the receiver has at the moment. Frequently, this flow regulation and the error handling are integrated.

3. The Network Layer:

The network layer controls the operation of the subnet. A key design issue is determining how packets are routed from source to destination. Routes can be based on static tables that are "wired into" the network and rarely changed. They can also be determined at the start of each conversation, for example, a terminal session (e.g., a login to a remote machine). Finally, they can be highly dynamic, being determined anew for each packet, to reflect the current network load. If too many packets are present in the subnet at the same time, they will get in one another's way, forming bottlenecks. The control of such congestion also belongs to the network layer. More generally, the quality of service provided (delay, transit time, jitter, etc.) is also a network layer issue. When a packet has to travel from one network to another to get to its destination,

many problems can arise. The addressing used by the second network may be different from the first one. The second one may not accept the packet at all because it is too large. The protocols may differ, and so on. It is up to the network layer to overcome all these problems to allow heterogeneous networks to be interconnected. In broadcast networks, the routing problem is simple, so the network layer is often thin or even nonexistent.

4. The Transport Layer:

The basic function of the transport layer is to accept data from above, split it up into smaller units if need be, pass these to the network layer, and ensure that the pieces all arrive correctly at the other end. Furthermore, all this must be done efficiently and in a way that isolates the upper layers from the inevitable changes in the hardware technology. The transport layer also determines what type of service to provide to the session layer, and, ultimately, to the users of the network. The most popular type of transport connection is an error-free point-to-point channel that delivers messages or bytes in the order in which they were sent. However, other possible kinds of transport service are the transporting of isolated messages, with no guarantee about the order of delivery, and the broadcasting of messages to multiple destinations. The type of service is determined when the connection is established. The transport layer is a true end-to-end layer, all the way from the source to the destination. In other words, a program on the source machine carries on a conversation with a similar program on the destination machine, using the message headers and control messages. In the lower layers, the protocols are between each machine and its immediate neighbors, and not between the ultimate source and destination machines, which may be separated by many routers.

5. The Session Layer:

The session layer allows users on different machines to establish sessions between them. Sessions offer various services, including dialog control (keeping track of whose turn it is to transmit), token management (preventing two parties from attempting the same critical operation at the same time), and synchronization (check pointing long transmissions to allow them to continue from where they were after a crash).

6. The Presentation Layer:

The presentation layer is concerned with the syntax and semantics of the information transmitted. In order to make it possible for computers with different data representations to communicate, the data structures to be exchanged can be defined in an abstract way, along with a standard encoding to be used "on the wire." The presentation layer manages these abstract data structures and allows higher-level data structures (e.g., banking records), to be defined and exchanged.

7. The Application Layer:

The application layer contains a variety of protocols that are commonly needed by users. One widely-used application protocol is HTTP (Hypertext Transfer Protocol), which is the basis for the World Wide Web. When a browser wants a Web page, it sends the name of the page it wants to the server using HTTP. The server then sends the page back. Other application protocols are used for file transfer, electronic mail, and network news.

Question No. 4

Explain the following:-

- a) LAN
- b) MAN
- c) WAN
- d) ARPANET

Answer: - a) LAN-Local Area Networks

Local area networks, generally called LANs, are privately-owned networks within a single building or campus of up to a few kilometers in size. They are widely used to connect personal computers and workstations in company offices and factories to share resources (e.g., printers) and exchange information. LANs are distinguished from other kinds of networks by three characteristics:

- (1) Their size,
- (2) Their transmission technology, and
- (3) Their topology.

LANs are restricted in size, which means that the worst-case transmission time is bounded and known in advance. Knowing this bound makes it possible to use certain kinds of designs that would not otherwise be possible. It also simplifies network management. LANs may use a transmission technology consisting of a cable to which all the machines are attached, like the telephone company party lines once used in rural areas. Traditional LANs run at speeds of 10 Mbps to 100 Mbps, have low delay (microseconds or nanoseconds), and make very few errors.

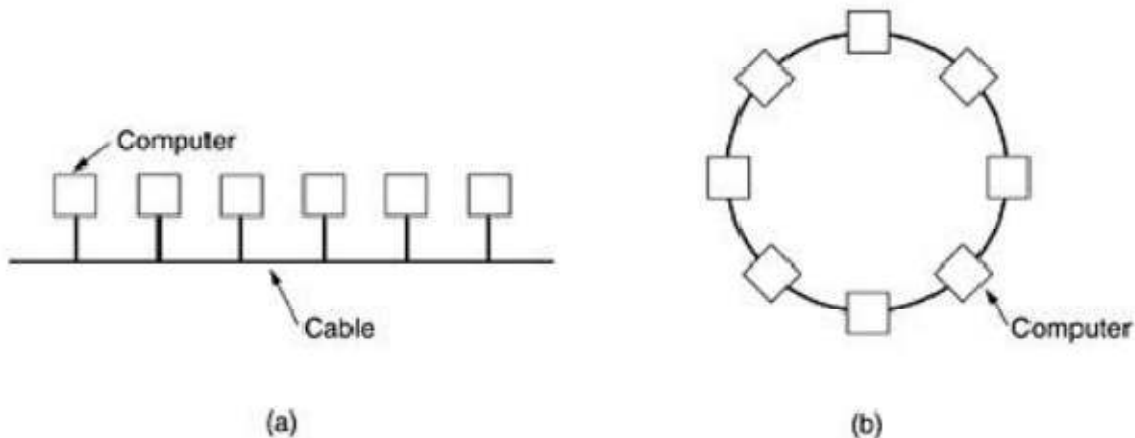

Newer LANs operate at up to 10 Gbps various topologies are possible for broadcast LANs. Figure1 shows two of them. In a bus (i.e., a linear cable) network, at any instant at most one machine is the master and is allowed to transmit. All other machines are required to refrain from sending. An arbitration mechanism is needed to resolve conflicts when two or more machines want to transmit simultaneously. The arbitration mechanism may be centralized or distributed. IEEE 802.3, popularly called Ethernet, for example, is a bus-based broadcast network with decentralized control, usually operating at 10 Mbps to 10 Gbps. Computers on an Ethernet can transmit whenever they want to; if two or more packets collide, each computer just waits a random time and tries again later.

A second type of broadcast system is the ring. In a ring, each bit propagates around on its own, not waiting for the rest of the packet to which it belongs. Typically, each bit circumnavigates the

entire ring in the time it takes to transmit a few bits, often before the complete packet has even been transmitted. As with all other broadcast systems, some rule is needed for arbitrating simultaneous accesses to the ring. Various methods, such as having the machines take turns, are in use. IEEE 802.5 (the IBM token ring), is a ring-based LAN operating at 4 and 16 Mbps. FDDI is another example of a ring network.

b) Metropolitan Area Network:

A metropolitan area network, or MAN, covers a city. The best-known example of a MAN is the cable television network available in many cities. This system grew from earlier community antenna systems used in areas with poor over-the-air television reception. In these early systems, a large antenna was placed on top of a nearby hill and signal was then piped to the subscribers' houses.

At first, these were locally-designed, ad hoc systems. Then companies began jumping into the business, getting contracts from city governments to wire up an entire city. The next step was television programming and even entire channels designed for cable only. Often these channels were highly specialized, such as all news, all sports, all cooking, all gardening, and so on. But from their inception until the late 1990s, they were intended for television reception only.

To a first approximation, a MAN might look something like the system shown in Fig.2. In this figure both television signals and Internet are fed into the centralized head end for subsequent distribution to people's homes.

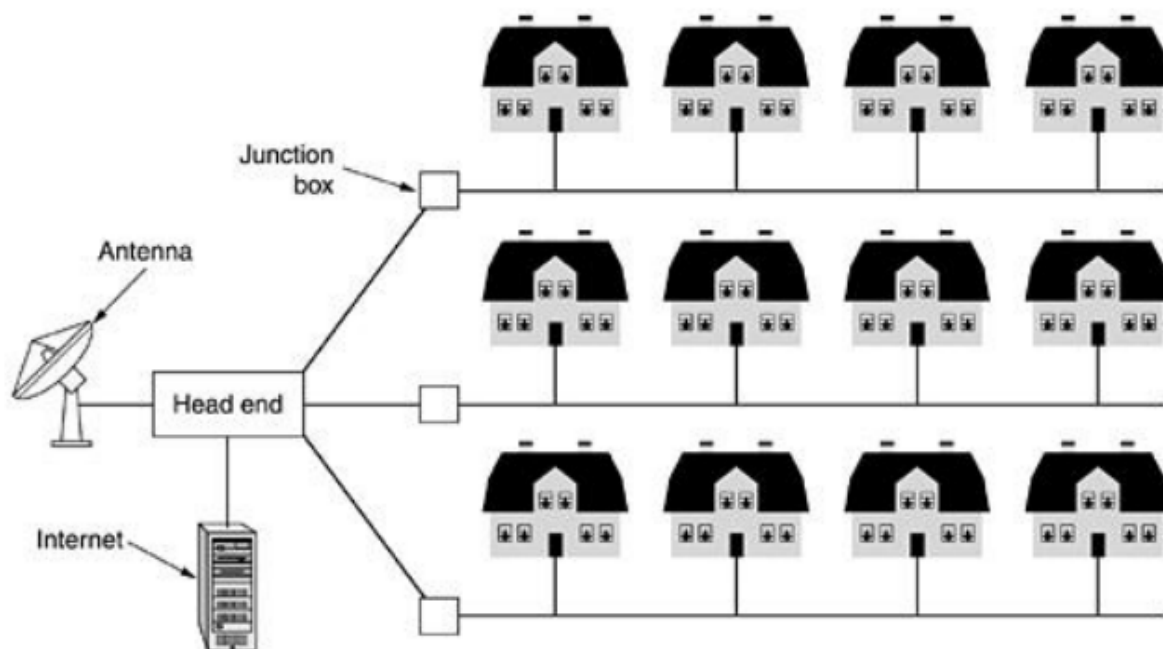

Cable television is not the only MAN. Recent developments in high-speed wireless Internet access resulted in another MAN, which has been standardized as IEEE 802.16. A MAN is implemented by a standard called DQDB (Distributed Queue Dual Bus) or IEEE 802.16. DQDB has two unidirectional buses (or cables) to which all the computers are attached.

c) Wide Area Network:

A wide area network, or WAN, spans a large geographical area, often a country or continent. It contains a collection of machines intended for running user (i.e., application) programs. These machines are called as hosts. The hosts are connected by a communication subnet, or just subnet for short. The hosts are owned by the customers (e.g., people's personal computers), whereas the communication subnet is typically owned and operated by a telephone company or Internet service provider. The job of the subnet is to carry messages from host to host, just as the telephone system carries words from speaker to listener. Separation of the pure communication aspects of the network (the subnet) from the application aspects (the hosts), greatly simplifies the complete network design.

In most wide area networks, the subnet consists of two distinct components: transmission lines and switching elements. Transmission lines move bits between machines. They can be made of copper wire, optical fiber, or even radio links. In most WANs, the network contains numerous transmission lines, each one connecting a pair of routers. If two routers that do not share a transmission line wish to communicate, they must do this indirectly, via other routers. When a packet is sent from one router to another via one or more intermediate routers, the packet is received at each intermediate router in its entirety, stored there until the required output line is free, and then forwarded. A subnet organized according to this principle is called a store-and-forward or packet-switched subnet. Nearly all wide area networks (except those using satellites) have store-and-forward subnets. When the packets are small and all the same size, they are often called cells.

The principle of a packet-switched WAN is so important. Generally, when a process on some host has a message to be sent to a process on some other host, the sending host first cuts the message into packets, each one bearing its number in the sequence. These packets are then injected into the network one at a time in quick succession. The packets are transported individually over the network and deposited at the receiving host, where they are reassembled into the original message and delivered to the receiving process. A stream of packets resulting from some initial message is illustrated. In this figure, all the packets follow the route ACE, rather than ABDE or ACDE. In some networks all packets from a given message must follow the same route; in others each packet is routed separately. Of course, if ACE is the best route, all packets may be sent along it, even if each packet is individually routed.

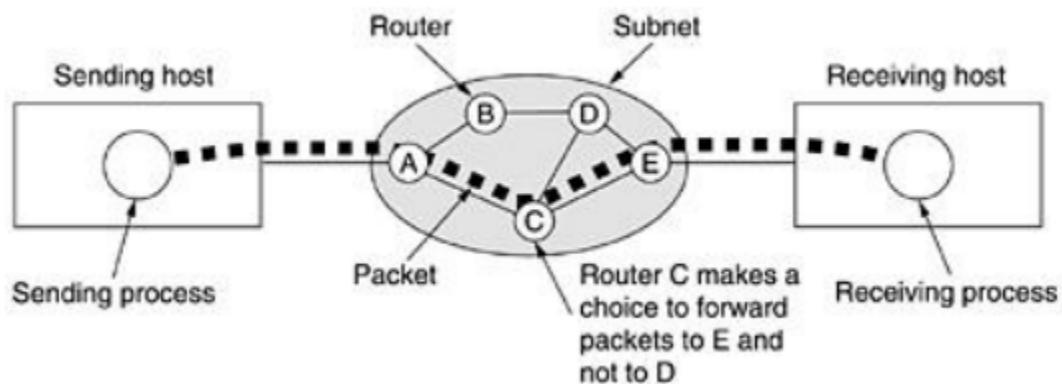

Not all WANs are packet switched. A second possibility for a WAN is a satellite system. Each router has an antenna through which it can send and receive. All routers can hear the output from

the satellite, and in some cases they can also hear the upward transmissions of their fellow routers to the satellite as well. Sometimes the routers are connected to a substantial point-to-point subnet, with only some of them having a satellite antenna. Satellite networks are inherently broadcast and are most useful when the broadcast property is important.

d) ARPANET:

The subnet would consist of minicomputers called IMPs (Interface Message Processors) connected by 56-kbps transmission lines. For high reliability, each IMP would be connected to at least two other IMPs. The subnet was to be a datagram subnet, so if some lines and IMPs were destroyed, messages could be automatically rerouted along alternative paths.

Each node of the network was to consist of an IMP and a host, in the same room, connected by a short wire. A host could send messages of up to 8063 bits to its IMP, which would then break these up into packets of at most 1008 bits and forward them independently toward the destination. Each packet was received in its entirety before being forwarded, so the subnet was the first electronic store-and-forward packet-switching network.

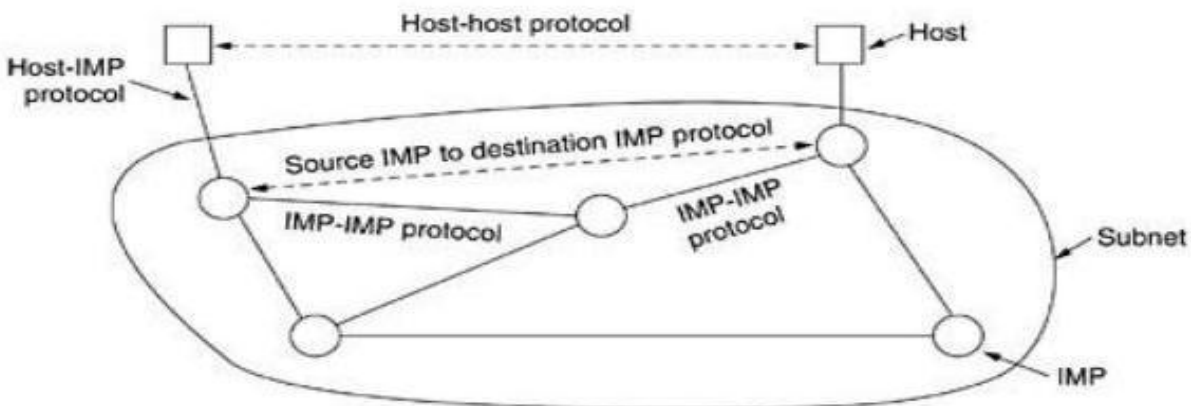

ORIGINAL ARPANET DESIGN

Each node of the network was to consist of an IMP and a host, in the same room, connected by a short wire. A host could send messages of up to 8063 bits to its IMP, which would then break these up into packets of at most 1008 bits and forward them independently toward the destination. Each packet was received in its entirety before being forwarded, so the subnet was the first electronic store-and-forward packet-switching network.

ARPA then put out a tender for building the subnet. Twelve companies bid for it. After evaluating all the proposals, ARPA selected BBN, a consulting firm in Cambridge, Massachusetts, and in December 1968, awarded it a contract to build the subnet and write the subnet software. BBN chose to use specially modified Honeywell DDP-316 minicomputers with 12K 16-bit words of core memory as the IMPs. The IMPs did not have disks, since moving parts were considered unreliable. The IMPs were interconnected by 56-kbps lines leased from telephone companies. Although 56 kbps is now the choice of teenagers who cannot afford ADSL or cable, it was then the best money could buy.

The software was split into two parts: subnet and host. The subnet software consisted of the IMP end of the host-IMP connection, the IMP-IMP protocol, and a source IMP to destination IMP protocol designed to improve reliability. The original ARPANET design is shown in Fig.10. Outside the subnet, software was also needed, namely, the host end of the host-IMP connection, the host-host protocol, and the application software. It soon became clear that BBN felt that when it had accepted a message on a host-IMP wire and placed it on the host-IMP wire at the destination, its job was done.

Question No. 5

What is TCP/IP Model? Explain the functions and protocols and services of each layer? Compare it with OSI Model.

Answer: - The TCP/IP MODEL:-

The TCP/IP reference model was developed prior to OSI model. The major design goals of this model were,

1. To connect multiple networks together so that they appear as a single network.
2. To survive after partial subnet hardware failures.
3. To provide a flexible architecture.

Unlike OSI reference model, TCP/IP reference model has only 4 layers. They are,

1. Host-to-Network Layer
2. Internet Layer
3. Transport Layer
4. Application Layer

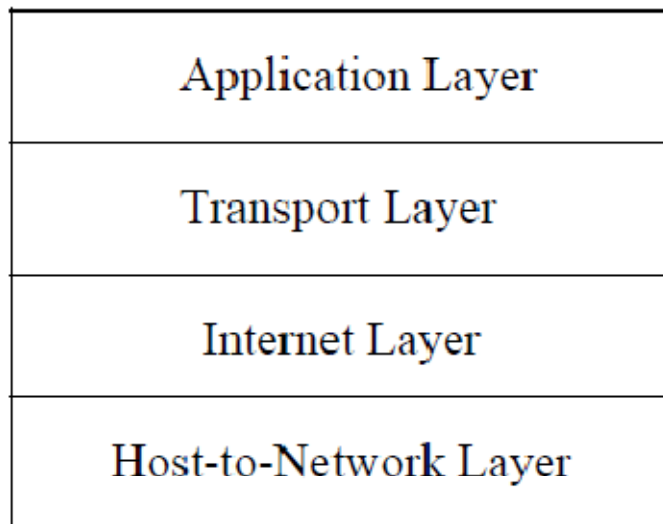

TCP/IP Reference model

1. Host-to-Network Layer:

The TCP/IP reference model does not really say much about what happens here, except to point out that the host has to connect to the network using some protocol so it can send IP packets to it. This protocol is not defined and varies from host to host and network to network.

2. Internet Layer:

This layer, called the internet layer, is the linchpin that holds the whole architecture together. Its job is to permit hosts to inject packets into any network and have them travel independently to the destination (potentially on a different network). They may even arrive in a different order than they were sent, in which case it is the job of higher layers to rearrange them, if in-order delivery is desired. Note that "internet" is used here in a generic sense, even though this layer is present in the Internet.

The internet layer defines an official packet format and protocol called IP (Internet Protocol). The job of the internet layer is to deliver IP packets where they are supposed to go. Packet routing is clearly the major issue here, as is avoiding congestion. For these reasons, it is reasonable to say that the TCP/IP internet layer is similar in functionality to the OSI network layer.

3. The Transport Layer:

The layer above the internet layer in the TCP/IP model is now usually called the transport layer. It is designed to allow peer entities on the source and destination hosts to carry on a conversation, just as in the OSI transport layer. Two end-to-end transport protocols have been defined here. The first one, TCP (Transmission Control Protocol), is a reliable connection-oriented protocol that allows a byte stream originating on one machine to be delivered without error on any other machine in the internet. It fragments the incoming byte stream into discrete messages and passes each one on to the internet layer. At the destination, the receiving TCP process reassembles the received messages into the output stream. TCP also handles flow control to make sure a fast sender cannot swamp a slow receiver with more messages than it can handle.

The second protocol in this layer, UDP (User Datagram Protocol), is an unreliable, connectionless protocol for applications that do not want TCP's sequencing or flow control and wish to provide their own. It is also widely used for one-shot, client-server-type request-reply queries and applications in which prompt delivery is more important than accurate delivery, such as transmitting speech or video. Since the model was developed, IP has been implemented on many other networks.

4. The Application Layer:

The TCP/IP model does not have session or presentation layers. On top of the transport layer is the application layer. It contains all the higher-level protocols. The early ones included virtual terminal (TELNET), file transfer (FTP), and electronic mail (SMTP), as shown in Fig.6.2. The virtual terminal protocol allows a user on one machine to log onto a distant machine and work there. The file transfer protocol provides a way to move data efficiently from one machine to another. Electronic mail was originally just a kind of file transfer, but later a specialized protocol (SMTP) was developed for it. Many other protocols have been added to these over the years: the Domain Name System (DNS) for mapping host names onto their network addresses, NNTP, the

protocol for moving USENET news articles around, and HTTP, the protocol for fetching pages on the World Wide Web, and many others.

Comparison of the OSI and TCP/IP Reference Models:

The OSI and TCP/IP reference models have much in common. Both are based on the concept of a stack of independent protocols. Also, the functionality of the layers is roughly similar. For example, in both models the layers up through and including the transport layer are there to provide an end-to-end, network-independent transport service to processes wishing to communicate. These layers form the transport provider. Again in both models, the layers above transport are application-oriented users of the transport service. Despite these fundamental similarities, the two models also have many differences.

Three concepts are central to the OSI model:

1. Services.
2. Interfaces.
3. Protocols.

Probably the biggest contribution of the OSI model is to make the distinction between these three concepts explicit. Each layer performs some services for the layer above it. The service definition tells what the layer does, not how entities above it access it or how the layer works. It defines the layer's semantics. A layer's interface tells the processes above it how to access it. It specifies what the parameters are and what results to expect. It, too, says nothing about how the layer works inside.

Finally, the peer protocols used in a layer are the layer's own business. It can use any protocols it wants to, as long as it gets the job done (i.e., provides the offered services). It can also change them at will without affecting software in higher layers. The TCP/IP model did not originally clearly distinguish between service, interface, and protocol, although people have tried to retrofit it after the fact to make it more OSI-like. For example, the only real services offered by the internet layer are SEND IP PACKET and RECEIVE IP PACKET.

As a consequence, the protocols in the OSI model are better hidden than in the TCP/IP model and can be replaced relatively easily as the technology changes. Being able to make such changes is one of the main purposes of having layered protocols in the first place. The OSI reference model was devised before the corresponding protocols were invented.

This ordering means that the model was not biased toward one particular set of protocols, a fact that made it quite general. The downside of this ordering is that the designers did not have much experience with the subject and did not have a good idea of which functionality to put in which layer.

Another difference is in the area of connectionless versus connection-oriented communication. The OSI model supports both connectionless and connection-oriented communication in the network layer, but only connection-oriented communication in the transport layer, where it counts (because the transport service is visible to the users). The TCP/IP model has only one mode in the network layer (connectionless) but supports both modes in the transport layer, giving the users a choice. This choice is especially important for simple request-response protocols.

Question No. 6

What is IP addressing? How it is classified? How is subnet addressing is performed?

Answer: -

Every host and router on the Internet has an IP address, which encodes its network number and host number. The combination is unique: in principle, no two machines on the Internet have the same IP address. All IP addresses are 32 bits long and are used in the Source address and Destination address fields of IP packets. It is important to note that an IP address does not actually refer to a host. It really refers to a network interface, so if a host is on two networks, it must have two IP addresses. However, in practice, most hosts are on one network and thus have one IP address.

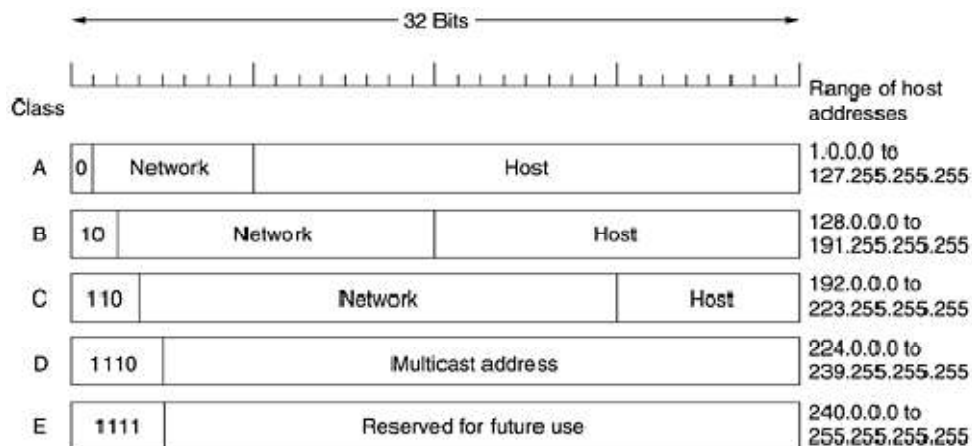

For several decades, IP addresses were divided into the five categories

The class A, B, C, and D formats allow for up to 128 networks with 16 million hosts each, 16,384 networks with up to 64K hosts, and 2 million networks (e.g., LANs) with up to 256 hosts each (although a few of these are special). Also supported is multicast, in which a datagram is directed to multiple hosts. Addresses beginning with 1111 are reserved for future use. Over 500,000 networks are now connected to the Internet, and the number grows every year. Network numbers are managed by a nonprofit corporation called ICANN (Internet Corporation for Assigned Names and Numbers) to avoid conflicts. In turn, ICANN has delegated parts of the address space to various regional authorities, which then dole out IP addresses to ISPs and other companies.

Network addresses, which are 32-bit numbers, are usually written in dotted decimal notation. In this format, each of the 4 bytes is written in decimal, from 0 to 255. For example, the 32-bit hexadecimal address C0290614 is written as 192.41.6.20. The lowest IP address is 0.0.0.0 and the highest is 255.255.255.255. The values 0 and -1 (all 1s) have special meanings, as shown in Fig. 5-56. The value 0 means this network or this host. The value of -1 is used as a broadcast address to mean all hosts on the indicated network.

The IP address 0.0.0.0 is used by hosts when they are being booted. IP addresses with 0 as network number refer to the current network. These addresses allow machines to refer to their own network without knowing its number (but they have to know its class to know how many 0s to include). The address consisting of all 1s allows broadcasting on the local network, typically a

LAN. The addresses with a proper network number and all 1s in the host field allow machines to send broadcast packets to distant LANs anywhere in the Internet (although many network administrators disable this feature). Finally, all addresses of the form 127.xx.yy.zz are reserved for loopback testing. Packets sent to that address are not put out onto the wire; they are processed locally and treated as incoming packets. This allows packets to be sent to the local network without the sender knowing its number.

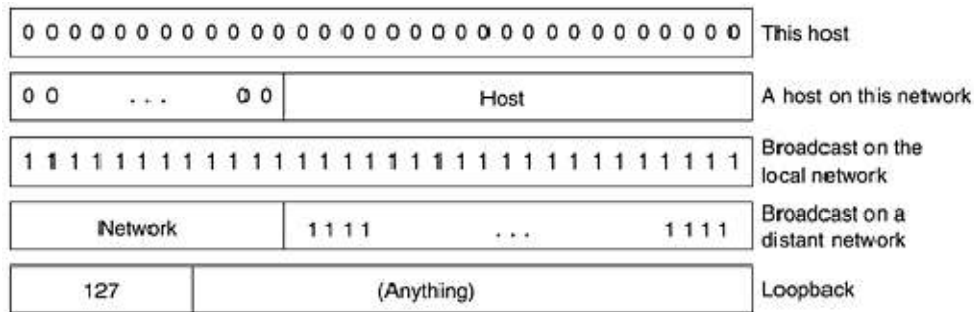

SOME SPECIAL IP ADDRESS

Sub netting

As we have seen, all the hosts in a network must have the same network number. This property of IP addressing can cause problems as networks grow. For example, consider a university that started out with one class B network used by the Computer Science Dept. for the computers on its Ethernet. A year later, the Electrical Engineering Dept. wanted to get on the Internet, so they bought a repeater to extend the CS Ethernet to their building. As time went on, many other departments acquired computers and the limit of four repeaters per Ethernet was quickly reached. A different organization was required. Getting a second network address would be hard to do since network addresses are scarce and the university already had enough addresses for over 60,000 hosts. The problem is the rule that a single class A, B, or C address refers to one network, not to a collection of LANs. As more and more organizations ran into this situation, a small change was made to the addressing system to deal with it. The solution is to allow a network to be split into several parts for internal use but still act like a single network to the outside world. A typical campus network nowadays might look like that of Fig. 5-57, with a main router connected to an ISP or regional network and numerous Ethernets spread around campus in different departments. Each of the Ethernets has its own router connected to the main router (possibly via a backbone LAN, but the nature of the inter router connection is not relevant here).

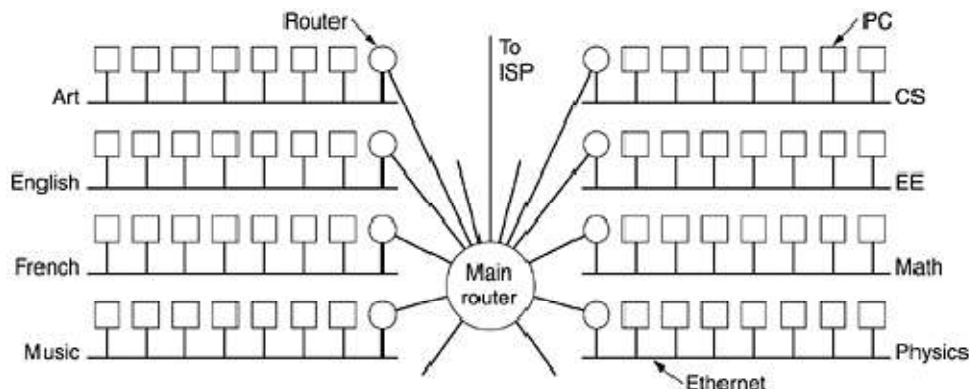

original byte streams. For simplicity, we will sometimes use just "TCP" to mean the TCP transport entity (a piece of software) or the TCP protocol (a set of rules). From the context it will be clear which is meant. For example, in "The user gives TCP the data," the TCP transport entity is clearly intended.

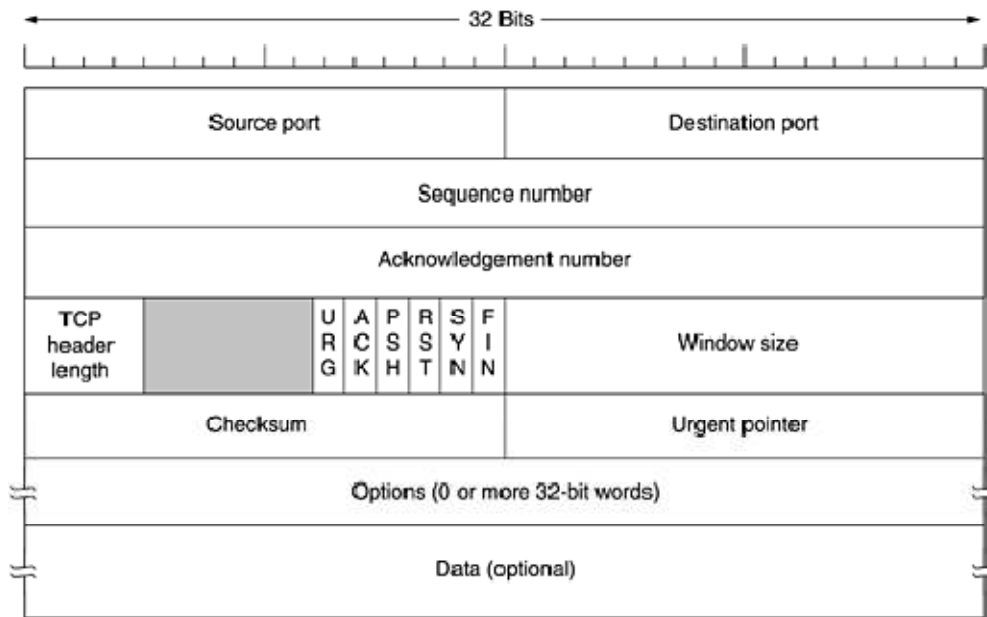

TCP HEADER

The IP layer gives no guarantee that datagrams will be delivered properly, so it is up to TCP to time out and retransmit them as need be. Datagrams that do arrive may well do so in the wrong order; it is also up to TCP to reassemble them into messages in the proper sequence. In short, TCP must furnish the reliability that most users want and that IP does not provide. Figure 8 shows the layout of a TCP segment. Every segment begins with a fixed-format, 20-byte header. The fixed header may be followed by header options. After the options, if any, up to 65,535 - 20 - 20 = 65,495 data bytes may follow, where the first 20 refer to the IP header and the second to the TCP header. Segments without any data are legal and are commonly used for acknowledgements and control messages.

The Source port and Destination port fields identify the local end points of the connection. The source and destination end points together identify the connection. The sequence number and Acknowledgement number fields perform their usual functions. Note that the latter specifies the next byte expected, not the last byte correctly received. Both are 32 bits long because every byte of data is numbered in a TCP stream. The TCP header length tells how many 32-bit words are contained in the TCP header.

This information is needed because the Options field is of variable length, so the header is, too. Technically, this field really indicates the start of the data within the segment, measured in 32-bit words, but that number is just the header length in words, so the effect is the same. Next comes a 6-bit field that is not used. The fact that this field has survived intact for over a quarter of a century is testimony to how well think out TCP is. Lesser protocols would have needed it to fix bugs in the original design. Now comes six 1-bit flags. URG is set to 1 if the Urgent pointer is in use. The Urgent

pointer is used to indicate a byte offset from the current sequence number at which urgent data are to be found. This facility is in lieu of interrupt messages. As we mentioned above, this facility is a bare-bones way of allowing the sender to signal the receiver without getting TCP itself involved in the reason for the interrupt.

The ACK bit is set to 1 to indicate that the Acknowledgement number is valid. If ACK is 0, the segment does not contain an acknowledgement so the Acknowledgement number field is ignored.

The PSH bit indicates PUSH ed data. The receiver is hereby kindly requested to deliver the data to the application upon arrival and not buffer it until a full buffer has been received (which it might otherwise do for efficiency).

The RST bit is used to reset a connection that has become confused due to a host crash or some other reason. It is also used to reject an invalid segment or refuse an attempt to open a connection. In general, if you get a segment with the RST bit on, you have a problem on your hands. The SYN bit is used to establish connections. The connection request has SYN = 1 and ACK = 0 to indicate that the piggyback acknowledgement field is not in use. The connection reply does bear an acknowledgement, so it has SYN = 1 and ACK = 1. In essence the SYN bit is used to denote CONNECTION REQUEST and CONNECTION ACCEPTED, with the ACK bit used to distinguish between those two possibilities.

The FIN bit is used to release a connection. It specifies that the sender has no more data to transmit. Both SYN and FIN segments have sequence numbers and are thus guaranteed to be processed in the correct order.

Flow control in TCP is handled using a variable-sized sliding window. The Window size field tells how many bytes may be sent starting at the byte acknowledged. A Window size field of 0 is legal and says that the bytes up to and including Acknowledgement number - 1 have been received, but that the receiver is currently badly in need of a rest and would like no more data for the moment. The receiver can later grant permission to send by transmitting a segment with the same Acknowledgement number and a nonzero Window size field.

II) UDP:

The Internet protocol suite supports a connectionless transport protocol, UDP (User Datagram Protocol). UDP provides a way for applications to send encapsulated IP data grams and send them without having to establish a connection. UDP is described in RFC 768. UDP transmits segments consisting of an 8-byte header followed by the payload. The header is shown BELOW. The two ports serve to identify the end points within the source and destination machines. When a UDP packet arrives, its payload is handed to the process attached to the destination port. This attachment occurs when BIND primitive or something similar is used, for TCP (the binding process is the same for UDP). In fact, the main value of having UDP over just using raw IP is the addition of the source and destination ports. Without the port fields, the transport layer would not know what to do with the packet. With them, it delivers segments correctly.

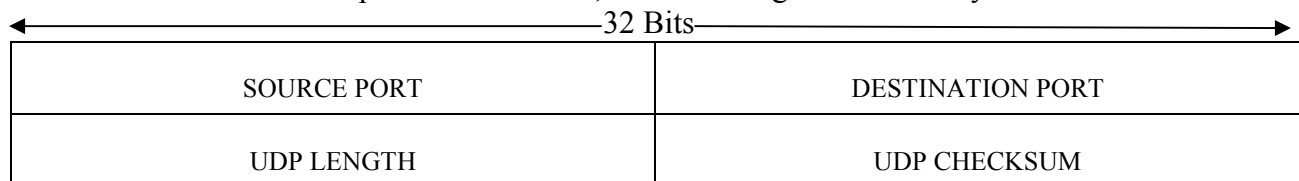

UDP HEADER

The source port is primarily needed when a reply must be sent back to the source. By copying the source port field from the incoming segment into the destination port field of the outgoing segment, the process sending the reply can specify which process on the sending machine is to get it.

The UDP length field includes the 8-byte header and the data. The UDP checksum is optional and stored as 0 if not computed (a true computed 0 is stored as all 1s). Turning it off is foolish unless the quality of the data does not matter (e.g., digitized speech). It is probably worth mentioning explicitly some of the things that UDP does not do. It does not do flow control, error control, or retransmission upon receipt of a bad segment. All of that is up to the user processes. What it does do is provide an interface to the IP protocol with the added feature of demultiplexing multiple processes using the ports. That is all it does. For applications that need to have precise control over the packet flow, error control, or timing, UDP provides just what the doctor ordered. One area where UDP is especially useful is in client-server situations. Often, the client sends a short request to the server and expects a short reply back. If either the request or reply is lost, the client can just time out and try again. Not only is the code simple, but fewer messages are required (one in each direction) than with a protocol requiring an initial setup.

Question No. 8

What is pure ALOHA and slotted ALOHA? Consider the delay of both at low load. Which one is less? Explain your answer.

Answer:-

ALOHA:

In the 1970s, Norman Abramson and his colleagues at the University of Hawaii devised a new and elegant method to solve the channel allocation problem. Their work has been extended by many researchers since then (Abramson, 1985). Although Abramson's work, called the ALOHA system, used ground-based radio broadcasting, the basic idea is applicable to any system in which uncoordinated users are competing for the use of a single shared channel. There are two versions of ALOHA: pure and slotted. They differ with respect to whether time is divided into discrete slots into which all frames must fit. Pure ALOHA does not require global time synchronization; slotted ALOHA does.

Pure ALOHA:

The basic idea of an ALOHA system is simple: let users transmit whenever they have data to be sent. There will be collisions, of course, and the colliding frames will be damaged. However, due to the feedback property of broadcasting, a sender can always find out whether its frame was destroyed by listening to the channel, the same way other users do. With a LAN, the feedback is immediate; with a satellite, there is a delay of 270 msec before the sender knows if the transmission was successful. If listening while transmitting is not possible for some reason, acknowledgements are needed. If the frame was destroyed, the sender just waits a random amount of time and sends it again. The waiting time must be random or the same frames will collide over and over, in lockstep. Systems in which multiple users share a common channel in a way that can lead to conflicts are widely known as contention systems.

We have made the frames all the same length because the throughput of ALOHA systems is maximized by having a uniform frame size rather than by allowing variable length frames. Whenever two frames try to occupy the channel at the same time, there will be a collision and both will be garbled. If the first bit of a new frame overlaps with just the last bit of a frame

almost finished, both frames will be totally destroyed and both will have to be retransmitted later. The checksum cannot (and should not) distinguish between a total loss and a near miss.

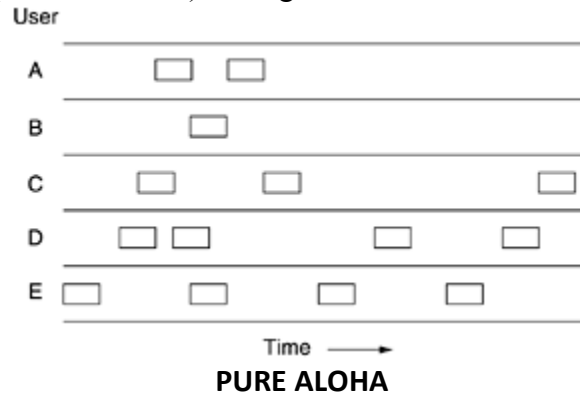

In 1972, Roberts published a method for doubling the capacity of an ALOHA system (Robert, 1972). His proposal was to divide time into discrete intervals, each interval corresponding to one frame. This approach requires the users to agree on slot boundaries.

One way to achieve synchronization would be to have one special station emit a pip at the start of each interval, like a clock. In Roberts' method, which has come to be known as slotted ALOHA, in contrast to Abramson's pure ALOHA, a computer is not permitted to send whenever a carriage return is typed. Instead, it is required to wait for the beginning of the next slot. Thus, the continuous pure ALOHA is turned into a discrete one. Since the vulnerable period is now halved, the probability of no other traffic during the same slot as our test frame is e^{-G} which leads to

Equation

$$S = Ge^{-G}$$

As you can see from Fig.3.3, slotted ALOHA peaks at $G = 1$, with a throughput of $S = 1/e$ or about 0.368, twice that of pure ALOHA. If the system is operating at $G = 1$, the probability of an empty slot is 0.368. The best we can hope for using slotted ALOHA is 37 percent of the slots empty, 37 percent successes, and 26 percent collisions. Operating at higher values of G reduces the number of empties but increases the number of collisions exponentially.

To see how this rapid growth of collisions with G comes about, consider the transmission of a test frame. The probability that it will avoid a collision is e^{-G} , the probability that all the other users are silent in that slot. The probability of a collision is then just $1 - e^{-G}$. The probability of a transmission requiring exactly k attempts, (i.e., $k - 1$ collisions followed by one success).

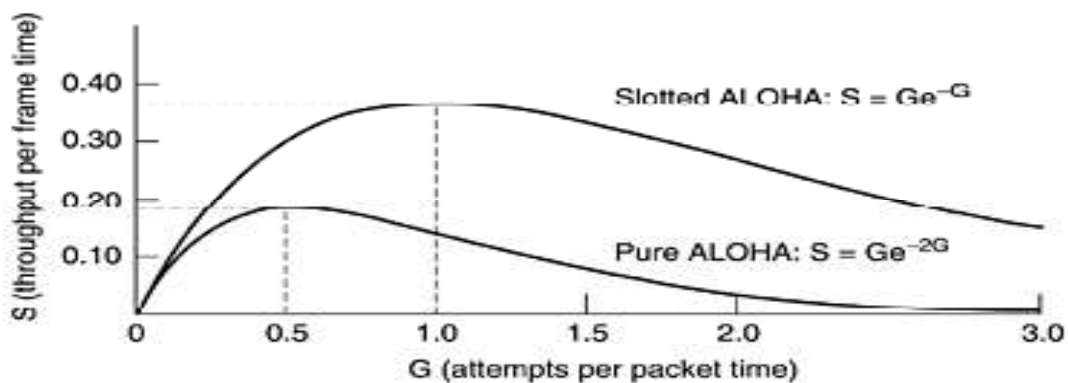

SLOTTED ALOHA

Question No. 9

Explain in detail CSMA Protocol in detail.

Answer:-

(i) 1-persistence CSMA

(ii) Non-persistence CSMA

(iii) P-persistence CSMA.

Carrier Sense Multiple Access Protocols:

With slotted ALOHA the best channel utilization that can be achieved is $1/e$. This is hardly surprising, since with stations transmitting at will, without paying attention to what the other stations are doing, there are bound to be many collisions. In local area networks, however, it is possible for stations to detect what other stations are doing, and adapt their behaviour accordingly. These networks can achieve a much better utilization than $1/e$. In this section we will discuss some protocols for improving performance. Protocols in which stations listen for a carrier (i.e., a transmission) and act accordingly are called carrier sense protocols. A number of them have been proposed. Kleinrock and Tobagi (1975) have analysed several such protocols in detail. Below we will mention several versions of the carrier sense protocols.

1.1-persistent CSMA:

The first carrier sense protocol that we will study here is called **1-persistent CSMA** (Carrier Sense Multiple Access). When a station has data to send, it first listens to the channel to see if anyone else is transmitting at that moment. If the channel is busy, the station waits until it becomes idle. When the station detects an idle channel, it transmits a frame. If a collision occurs, the station waits a random amount of time and starts all over again. The protocol is called 1-persistent because the station transmits with a probability of 1 when it finds the channel idle. The propagation delay has an important effect on the performance of the protocol.

There is a small chance that just after a station begins sending, another station will become ready to send and sense the channel. If the first station's signal has not yet reached the second one, the latter will sense an idle channel and will also begin sending, resulting in a collision. The longer the propagation delay, the more important this effect becomes, and the worse the performance of the protocol.

Even if the propagation delay is zero, there will still be collisions. If two stations become ready in the middle of a third station's transmission, both will wait politely until the transmission ends and then both will begin transmitting exactly simultaneously, resulting in a collision. If they were not so impatient, there would be fewer collisions. Even so, this protocol is far better than pure ALOHA because both stations have the decency to desist from interfering with the third station's frame. Intuitively, this approach will lead to a higher performance than pure ALOHA. Exactly the same holds for slotted ALOHA.

2. Non-persistent CSMA:

A second carrier sense protocol is **non-persistent CSMA**. In this protocol, a conscious attempt is made to be less greedy than in the previous one. Before sending, a station senses the channel. If no one else is sending, the station begins doing so itself. However, if the channel is already in use, the station does not continually sense it for the purpose of seizing it immediately upon detecting the end of the previous transmission. Instead, it waits a random period of time and then

repeats the algorithm. Consequently, this algorithm leads to better channel utilization but longer delays than 1-persistent CSMA.

3. P-persistent CSMA:

The last protocol is **p-persistent CSMA**. It applies to slotted channels and works as follows. When a station becomes ready to send, it senses the channel. If it is idle, it transmits with a probability p . With a probability $q = 1 - p$, it defers until the next slot. If that slot is also idle, it either transmits or defers again, with probabilities p and q . This process is repeated until either the frame has been transmitted or another station has begun transmitting. In the latter case, the unlucky station acts as if there had been a collision (i.e., it waits a random time and starts again). If the station initially senses the channel busy, it waits until the next slot and applies the above algorithm. Figure 4 shows the computed throughput versus offered traffic for all three protocols, as well as for pure and slotted ALOHA.

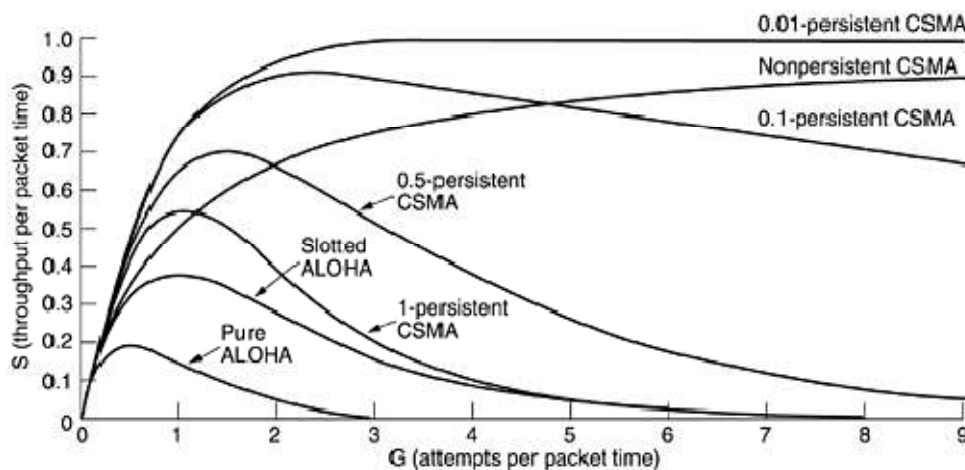

Question No. 10

Explain in detail CSMA/CD Protocol in detail. How it detects collision.

Answer:-

Persistent and non-persistent CSMA protocols are clearly an improvement over ALOHA because they ensure that no station begins to transmit when it senses the channel busy. Another improvement is for stations to abort their transmissions as soon as they detect a collision. In other words, if two stations sense the channel to be idle and begin transmitting simultaneously, they will both detect the collision almost immediately. Rather than finish transmitting their frames, which are irretrievably garbled anyway, they should abruptly stop transmitting as soon as the collision is detected. Quickly terminating damaged frames saves time and bandwidth.

This protocol, known as CSMA/CD (CSMA with Collision Detection) is widely used on LANs in the MAC sub layer. In particular, it is the basis of the popular Ethernet LAN, so it is worth devoting some time to looking at it in detail. CSMA/CD, as well as many other LAN protocols, uses the conceptual model of Fig.5. At the point marked to, a station has finished transmitting its frame. Any other station having a frame to send may now attempt to do so. If two or more stations decide to transmit simultaneously, there will be a collision. Collisions can be detected by

looking at the power or pulse width of the received signal and comparing it to the transmitted signal.

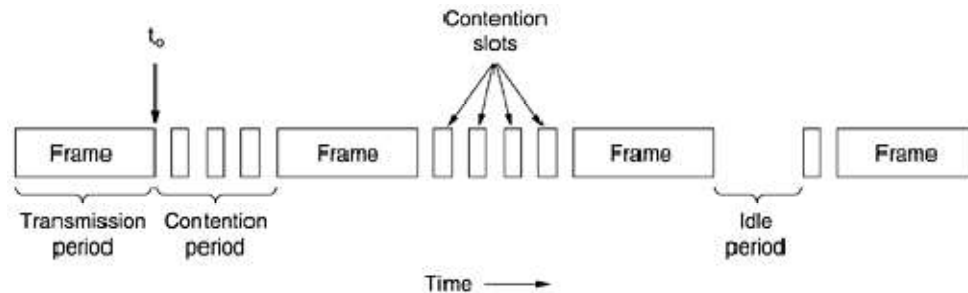

After a station detects a collision, it aborts its transmission, waits a random period of time, and then tries again, assuming that no other station has started transmitting in the meantime. Therefore, our model for CSMA/CD will consist of alternating contention and transmission periods, with idle periods occurring when all stations are quiet (e.g., for lack of work).

Now let us look closely at the details of the contention algorithm. Suppose that two stations both begin transmitting at exactly time t_0 . How long will it take them to realize that there has been a collision? The answer to this question is vital to determining the length of the contention period and hence what the delay and throughput will be. The minimum time to detect the collision is then just the time it takes the signal to propagate from one station to the other.

Question No. 11

What is IPv6? Explain its advantages over IPv4. Also explain its frame format.

Answer:-

IPv4 provides the host-to-host communication between systems in the Internet. Although IPv4 is well designed, data communication has evolved since the inception of IPv4 in the 1970s. IPv4 has some deficiencies that make it unsuitable for the fast-growing Internet.

- Despite all short-term solutions, such as subnetting, classless addressing, and NAT, address depletion is still a long-term problem in the Internet.
- The Internet must accommodate real-time audio and video transmission. This type of transmission requires minimum delay strategies and reservation of resources not provided in the IPv4 design.
- The Internet must accommodate encryption and authentication of data for some applications. No encryption or authentication is provided by IPv4.

To overcome these deficiencies, IPv6 (Internetworking Protocol, version 6), also known as IPng (Internetworking Protocol, next generation), was proposed and is now a standard. In IPv6, the Internet protocol was extensively modified to accommodate the unforeseen growth of the Internet. The format and the length of the IP address were changed along with the packet format. Related protocols, such as ICMP, were also modified. Other protocols in the network layer, such as ARP, RARP, and IGMP, were either deleted or included in the ICMPv6 protocol (see Chapter 21). Routing protocols, such as RIP and OSPF (see Chapter 22), were also slightly modified to accommodate these changes. Communications experts predict that IPv6 and its related protocols will soon replace the current IP version. In this section first we discuss IPv6. Then we explore the strategies used for the transition from version 4 to version 6. The adoption of IPv6 has been

slow. The reason is that the original motivation for its development, depletion of IPv4 addresses, has been remedied by short-term strategies such as classless addressing and NAT. However, the fast-spreading use of the Internet, and new services such as mobile IP, IP telephony, and IP-capable mobile telephony, may eventually require the total replacement of IPv4 with IPv6.

Advantages

The next-generation IP, or IPv6, has some advantages over IPv4 that can be summarized as follows:

1. **Larger address space:** An IPv6 address is 128 bits long, Compared with the 32-bit address of IPv4, this is a huge (2^96) increase in the address space.
2. **Better header format.** IPv6 uses a new header format in which options are separated from the base header and inserted, when needed, between the base header and the upper-layer data. This simplifies and speeds up the routing process because most of the options do not need to be checked by routers.
3. **New options.** IPv6 has new options to allow for additional functionalities.
4. **Allowance for extension.** IPv6 is designed to allow the extension of the protocol if required by new technologies or applications.
5. **Support for resource allocation.** In IPv6, the type-of-service field has been removed, but a mechanism (called *flow label*) has been added to enable the source to request special handling of the packet. This mechanism can be used to support traffic such as real-time audio and video.
6. **Support for more security.** The encryption and authentication options in IPv6 provide confidentiality and integrity of the packet.

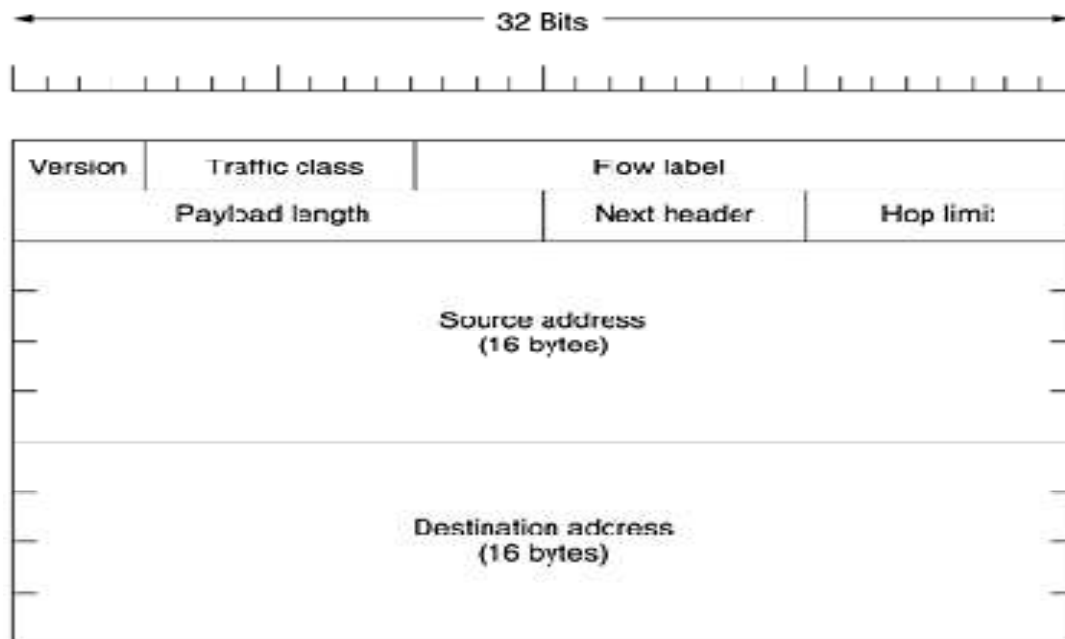

IPv6 Packet Format

1. Version (4 bits)

The constant 6 (bit sequence 0110).

2. Traffic Class (8 bits)

The bits of this field hold two values. The 6 most-significant bits are used for DSCP, which is used to classify packets. The remaining two bits are used for ECN, priority values subdivide into ranges: traffic where the source provides congestion control and non-congestion control traffic.

3. Flow Label (20 bits)

Originally created for giving real-time applications special service. Flow Label specifications and minimum requirements are described, and first uses of this field are emerging.

4. Payload Length (16 bits)

The size of the payload in octets, including any extension headers. The length is set to zero when a Hop-by-Hop extension header carries a Jumbo Payload option.

5. Next Header (8 bits)

Specifies the type of the next header. This field usually specifies the transport layer protocol used by a packet's payload, when extension headers are present in the packet this field indicates which extension header follows. The values are shared with those used for the IPv4 protocol field, as both fields have the same function (see List of IP protocol numbers).

6. Hop Limit (8 bits)

Replaces the time to live field of IPv4. This value is decremented by one at each intermediate node the packet visits. When the counter reaches 0 the packet is discarded.

7. Source Address (128 bits)

The IPv6 address of the sending node.

8. Destination Address (128 bits)

The IPv6 address of the destination node(s)